

# Model RDC-MX Robotic Depalletizing Cell

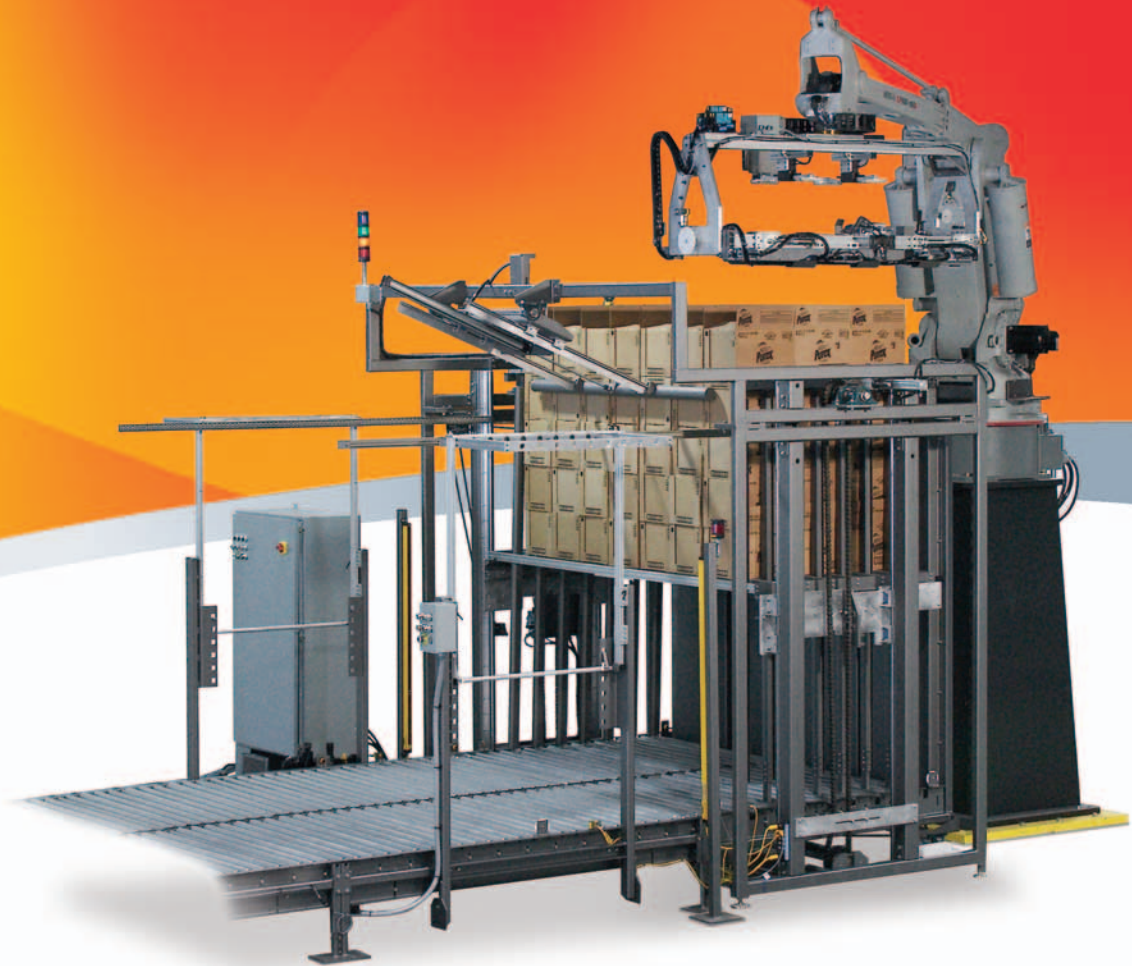

## Robotic depalletizer for unloading large pallets of product.

The Pearson Model RDC-MX Robotic Depalletizing Cell is the solution for unloading palletized product. Each RDC-MX Robotic Depalletizing Cell is custom-designed for your project requirements and plant layout, but they all feature a multi-axis articulated arm robot, which provides the ultimate in flexibility and reliable operation. With fast, pre-programmed changeovers and customizable end-of-arm tooling, the RDC-MX can easily depalletize a variety of different products. Plus, as your needs change, the RDC-MX can change with you.

The RDC-MX is designed to receive a full pallet from a conveyor system. Once the RDC-MX secures the pallet, a multi-axis robotic arm moves over the pallet, picks a specified amount of product off of the pallet and transfers it onto a discharge conveyor. The RDC-MX removes product layer by

layer until the pallet is empty. The empty pallet is then discharged from the system to allow for another pallet to enter.

The RDC-MX offers the following features:

- **Highly reliable robotic arm design with MTBF of over 60,000 hours**
- **Flexibility to depalletize a variety of product and pallet patterns**
- **Fully-interlocked perimeter guard package**
- **Multiple infeed/discharge configurations**
- **Customizable end-of-arm tooling**

Like all Pearson products, the RDC-MX is backed by Pearson's experienced factory professionals as well as one of the largest teams of PMMI certified regional service technicians in the industry, available 24-hours a day, 7-days a week - worldwide.

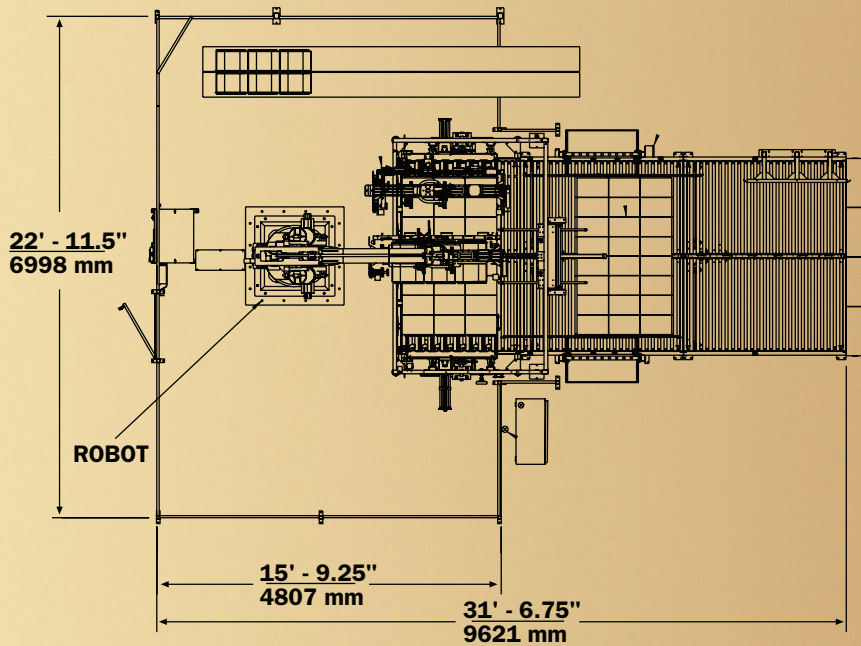

PLAN

Plan and elevation views shown are for example purposes only. Footprint of the RDC-MX Robotic Depalletizing Cell is dependent on project requirements. Please contact Pearson Packaging Systems for a custom layout.

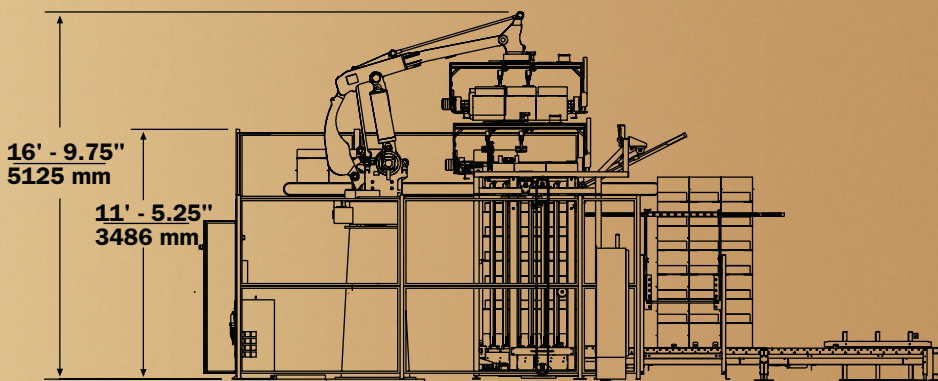

ELEVATION

## UTILITY REQUIREMENTS RDC-MX

### Electrical:

230/460V, 3-phase,  
60 Hz Std.

### Pneumatic:

Dependent on project requirements.

### Shipping Weight:

Dependent on final configuration.

